

**MOTOR SPECIFICATION SHEET**

MODEL : SF-PRB 5.5kW 4P  
USED FOR : 380V 50Hz  
MANUFACTURER : MITSUBISHI ELECTRIC CORPORATION

DESCRIPTION	DETAIL
PHASE	3
MODEL NAME	SF-PRB
RATED OUTPUT	5.5 kW
POLE	4
CODE	
OUTLINE DRAWING NO.	BD27676-*
RATED VOLTAGE (V)	380
RATED FREQUENCY (Hz)	50
RATED CURRENT (A)	11.3
RATED SPEED (min <sup>-1</sup> )	1460
RATED EFFICIENCY	91.2%
EFFICIENCY CLASS	IE3
THERMAL CLASS	130 (B)
RATING	S1 (CONTINUOUS)
ENCLOSURE CONSTRUCTION	TOTALLY ENCLOSED FAN COOLED
DEGREES OF PROTECTION	IP44
METHOD OF COOLING	IC411
FRAME NO.	132S
WEIGHT (kg)	69
STANDARD	JIS C 4213, JEC-2137-2000
INSTALLATION	FOOT MOUNTED
ROTATION	CCW (VIEWED FROM SHAFT END)
BEARING	LOAD SIDE : 6308ZZ
	OPPOSITE SIDE : 6208ZZ
BEARING GREASE	UREA GREASE
NOISE (dB.A)*	56
VIBRATION	V10
CIRCUMSTANCE CONDITION	AMBIENT TEMPERATURE : -20 ~ +40°C
	AMBIENT HUMIDITY : 95% RH (NO CONDENSATION)
	ABOVE SEA LEVEL : 1000m OR BELOW
	ENVIRONMENT : NO CORROSIVE/EXPLOSIVE GAS, NO STEAM OR CONDENSATION, MINIMAL DUST.
COLOR	MUNSELL N7 (GRAY)
TERMINAL BOX	NO. OF LEAD WIRES : MOTOR = 6 , BRAKE = 3
	SOURCE CONNECTION : TERMINAL BLOCK
SHAFT SWING	≤0.03mm
MATERIAL	FRAME : STEEL PLATE
	BRACKET LOAD SIDE : ALUMINIUM
	OPPOSITE SIDE : CAST IRON
	SHAFT : CARBON STEEL
	STATOR CORE : ELECTRICAL STEEL
	WIRE : ENAMELLED COPPER MAGNET WIRE
	ROTOR CORE : ELECTRICAL STEEL
	CONDUCTOR : ALUMINIUM
	TERMINAL BOX : STEEL PLATE
	PAINTING : ACRYLIC RESIN
BRAKE	TYPE : TB-A7.5H (DC)
	RATED BRAKING TORQUE : 75 N.m
	POWER SUPPLY UNIT : PROVIDED BY BUILT INTO MOTOR.
PRODUCTION COUNTRY	JAPAN

\*Value indicates representative value, not guaranteed value.

Specifications subject to change without notice.

<b>SPECIFICATION SHEET NO.</b>				
SS-M-2693-A				

# TYPE SF-PRB SUPER-LINE THREE PHASE INDUCTION MOTOR

OUT LINE  
DIMENSION IN mm

## INDOOR USE TYPE

TOTALLY ENCLOSED FAN COOLED  
 PROTECTION DEGREE: IP44 (BRAKE: IP20)  
 COOLING METHOD: IC411  
 WITH TYPE TB-A7.5 ELECTROMAGNETIC BRAKE  
 BRAKING TORQUE 75N·m FRAME NO. 132S

CUSTOMER

USER

FOR

CUST'S ORDER NO.

QUANTITY

UNIT (S)

MFG ORDER NO.

YOUR ORDER	KW·POLES	VOLT	HERTZ	MASS kg/UNIT	STYLE NO.
	5.5kW 4P	380V	50Hz	69	

IE Code-Rated Eff	
5.5kW 4P	IE3-91.2%

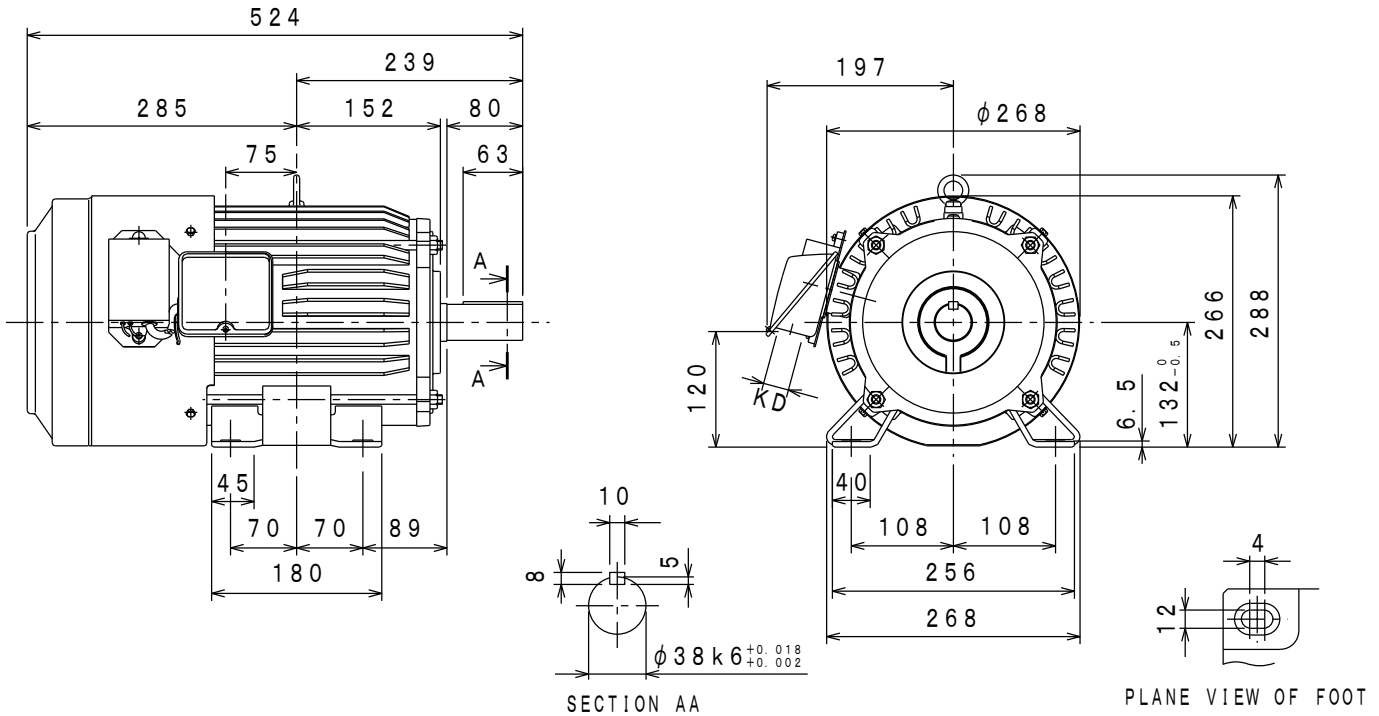

	RATING	TH. CLASS	AMB. TEMP	BEARINGS		NO. OF TERMINALS		VIEWED FROM DRIVE END		COLOUR	KD	BRAKING TORQUE
				LOAD SIDE	OPPOSITE SIDE	MOTOR	BRAKE	DIRECT. OF TERMINAL BOX	ROTATION			
	S1	130 (B)	40° C	6308ZZ	6208ZZ	6	3	A (LEFT)	CCW	MUNSELL N7	φ27	ABOVE 150%

- NOTE: 1. LEADS FOR MAIN POWER AND BRAKE ARE CONNECTED WITH TERMINAL BOARD, AND BRAKE IS TURNED OFF AT THE SAME TIME WITH MAIN POWER.  
 IN CONNECTING THEM SEPARATELY, REMOVE BRAKE LEADS FROM TERMINAL BOARD.  
 2. WITH POWER-SUPPLY UNIT (FOR 400V) FOR BRAKE. (OVER-EXCITATION TYPE)  
 3. PLEASE REFER TO BD08258 FOR THE BRAKE CONNECTING WIRES.

	DRAWN	APPROVED
SCALE NTS		
DATE		

(和文: BD27675)

MITSUBISHI ELECTRIC CORP., JAPAN  
 NAGOYA WORKS

改型			

図面  
 番号  
 DWG. **BD27676-\***  
 NO.

CAD(2D)