

MOTOR SPECIFICATION SHEET

MODEL : SF-PRB 22kW 4P
USED FOR : 380V 50Hz
MANUFACTURER : MITSUBISHI ELECTRIC CORPORATION

DESCRIPTION	DETAIL
PHASE	3
MODEL NAME	SF-PRB
RATED OUTPUT	22 kW
POLE	4
CODE	
OUTLINE DRAWING NO.	BD39543-*
RATED VOLTAGE (V)	380
RATED FREQUENCY (Hz)	50
RATED CURRENT (A)	42
RATED SPEED (min ⁻¹)	1475
RATED EFFICIENCY	93.7%
EFFICIENCY CLASS	IE3
THERMAL CLASS	130 (B)
RATING	S1 (CONTINUOUS)
ENCLOSURE CONSTRUCTION	TOTALLY ENCLOSED FAN COOLED
DEGREES OF PROTECTION	IP44
METHOD OF COOLING	IC411
FRAME NO.	180M
WEIGHT (kg)	200
STANDARD	JIS C 4213, JEC-2137-2000
INSTALLATION	FOOT MOUNTED
ROTATION	CCW (VIEWED FROM SHAFT END)
BEARING	LOAD SIDE : 6213ZZ OPPOSITE SIDE : 6310ZZ
BEARING GREASE	UREA GREASE
NOISE (dB.A)*	66
VIBRATION	V15
CIRCUMSTANCE CONDITION	AMBIENT TEMPERATURE : -20 ~ +40°C AMBIENT HUMIDITY : 85% RH (NO CONDENSATION) ABOVE SEA LEVEL : 1000m OR BELOW ENVIRONMENT : NO CORROSIVE/EXPLOSIVE GAS, NO STEAM OR CONDENSATION, MINIMAL DUST.
COLOR	MUNSELL N7 (GRAY)
TERMINAL BOX	NO. OF LEAD WIRES : MOTOR = 6 , BRAKE = 2 SOURCE CONNECTION : LEAD WIRES
SHAFT SWING	≤0.05mm
MATERIAL	FRAME : STEEL PLATE BRACKET LOAD SIDE : ALUMINIUM OPPOSITE SIDE : CAST IRON SHAFT : CARBON STEEL STATOR CORE : ELECTRICAL STEEL WIRE : ENAMELLED COPPER MAGNET WIRE ROTOR CORE : ELECTRICAL STEEL CONDUCTOR : ALUMINIUM TERMINAL BOX : STEEL PLATE PAINTING : ACRYLIC RESIN
BRAKE	TYPE : ESB-220 (DC) RATED BRAKING TORQUE : 300 N.m POWER SUPPLY UNIT : PROVIDED BY CUSTOMER. (REFER TO OUTLINE DRAWING.)
PRODUCTION COUNTRY	JAPAN

*Value indicates representative value, not guaranteed value.

Specifications subject to change without notice.

SPECIFICATION SHEET NO.

SS-M-3698-A

TYPE SF-PRB SUPER-LINE THREE PHASE INDUCTION MOTOR

OUT LINE
DIMENSION IN mm

INDOOR USE TYPE

TOTALLY ENCLOSED FAN COOLED
PROTECTION DEGREE: IP44, COOLING METHOD: IC411
BRAKE (PROTECTION DEGREE: IP44)
WITH TYPE ESB-220 ELECTRO MAGNETIC BRAKE
VOLT: D. C 90V, BRAKING TORQUE: 300N·m FRAME NO. 180M

CUSTOMER _____
USER _____
FOR _____
CUST' S ORDER NO. _____
QUANTITY _____ UNIT (S) _____
MFG ORDER NO. _____

YOUR ORDER	kW · POLES	VOLT	HERTZ	MASS kg/UNIT	STYLE NO.
	22 kW 4P	380V	50Hz	200	

IE Code-Rated Eff		
22 kW 4P	IE3	93.7%

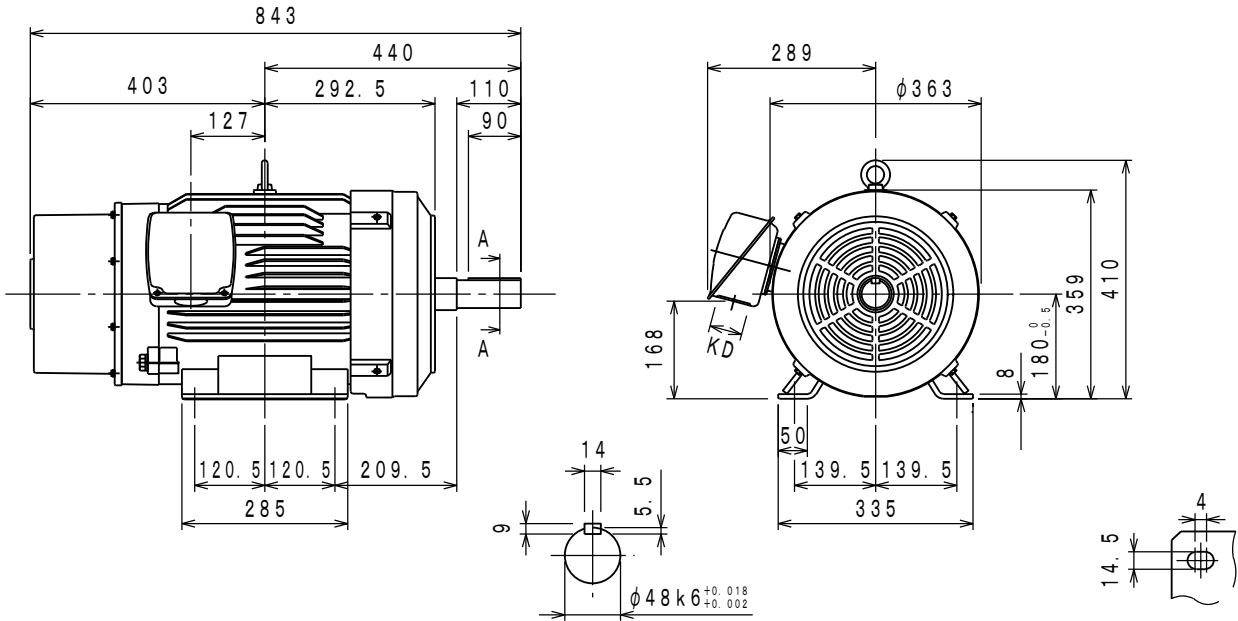

SECTION AA

PLANE VIEW OF FOOT

	RATING	TH. CLASS	AMB. TEMP	BEARINGS		NO. OF TERMINALS		VIEWED FROM DRIVE END		COLOUR	KD	BRAKING TORQUE
				LOAD SIDE	OPPOSITE SIDE	MOTOR	BRAKE	DIRECT. OF TERMINAL BOX	ROTATION			
	S 1	130 (B)	40° C	6213ZZ	6310ZZ	6	2	A (LEFT)	CCW	MUNSELL N7	phi 56	ABOVE 150%

1. THE POWER-SUPPLY UNIT FOR THE BRAKE IS NOT ATTACHED. PLEASE ARRANGE BY YOU, AND INSTALL IT IN THE CONTROL BOARD.
2. THE TYPE OF POWER-SUPPLY UNIT IS GIVEN BELOW. THE BRAKE CAN BE USED WITH DC90V. THE OTHER TYPES OF POWER SUPPLY UNIT CAN HEAT THE BRAKE COIL AND SHORTEN ITS LIFE SPAN.

TYPE: HD-120M (OSAKI ELECTRIC CLUTCH BRAKE Co., Ltd.)

INPUT: SINGLE PHASE AC200V/220V

OUTPUT (BRAKE INPUT): DC180V WHEN RELEASING THE BRAKE

DC 45V WHEN KEEPING THE RELEASING OF THE BRAKE } INPUT AC200V LOAD RUNNING

3. PLEASE GIVE SINGLE PHASE AC200V FOR THE BRAKE POWER-SUPPLY UNIT.

	DRAWN	APPROVED
	SCALE NTS	
	DATE Mar. 14. '19	

CAD (2D)

MITSUBISHI ELECTRIC CORP., JAPAN
NAGOYA WORKS

CHANGE			

図面番号
DWG. NO. BD39543-*