

**MOTOR SPECIFICATION SHEET**

MODEL : SF-PRB 1.5kW 4P  
USED FOR : 380V 50Hz  
MANUFACTURER : MITSUBISHI ELECTRIC CORPORATION

DESCRIPTION	DETAIL
PHASE	3
MODEL NAME	SF-PRB
RATED OUTPUT	1.5 kW
POLE	4
CODE	
OUTLINE DRAWING NO.	BD27208-A
RATED VOLTAGE (V)	380
RATED FREQUENCY (Hz)	50
RATED CURRENT (A)	3.4
RATED SPEED (min <sup>-1</sup> )	1445
RATED EFFICIENCY	86.7%
EFFICIENCY CLASS	IE3
THERMAL CLASS	120 (E)
RATING	S1 (CONTINUOUS)
ENCLOSURE CONSTRUCTION	TOTALLY ENCLOSED FAN COOLED
DEGREES OF PROTECTION	IP44
METHOD OF COOLING	IC411
FRAME NO.	90L
WEIGHT (kg)	26
STANDARD	JIS C 4213, JEC-2137-2000
INSTALLATION	FOOT MOUNTED
ROTATION	CCW (VIEWED FROM SHAFT END)
BEARING	LOAD SIDE : 6205ZZ OPPOSITE SIDE : 6205ZZ
BEARING GREASE	UREA GREASE
NOISE (dB.A)*	49
VIBRATION	V15
CIRCUMSTANCE CONDITION	AMBIENT TEMPERATURE : -20 ~ +40°C AMBIENT HUMIDITY : 95% RH (NO CONDENSATION) ABOVE SEA LEVEL : 1000m OR BELOW ENVIRONMENT : NO CORROSIVE/EXPLOSIVE GAS, NO STEAM OR CONDENSATION, MINIMAL DUST.
COLOR	MUNSELL N7 (GRAY)
TERMINAL BOX	NO. OF LEAD WIRES : MOTOR = 3 , BRAKE = 3 SOURCE CONNECTION : TERMINAL BLOCK
SHAFT SWING	≤0.03mm
MATERIAL	FRAME : STEEL PLATE BRACKET LOAD SIDE : ALUMINIUM OPPOSITE SIDE : CAST IRON SHAFT : CARBON STEEL STATOR CORE : ELECTRICAL STEEL WIRE : ENAMELLED COPPER MAGNET WIRE ROTOR CORE : ELECTRICAL STEEL CONDUCTOR : ALUMINIUM TERMINAL BOX : STEEL PLATE PAINTING : ACRYLIC RESIN
BRAKE	TYPE : TB-A1.5H (DC) RATED BRAKING TORQUE : 15 N.m POWER SUPPLY UNIT : PROVIDED BY BUILT INTO MOTOR.
PRODUCTION COUNTRY	JAPAN

\*Value indicates representative value, not guaranteed value.

Specifications subject to change without notice.

<b>SPECIFICATION SHEET NO.</b>				
SS-M-9690-A				

# TYPE SF-PRB SUPER-LINE THREE PHASE INDUCTION MOTOR

OUT LINE  
DIMENSION IN mm

## INDOOR USE TYPE

TOTALLY ENCLOSED FAN COOLED  
PROTECTION DEGREE: IP44 (BRAKE: IP20)  
COOLING METHOD: IC411  
WITH TYPE TB-A1.5H ELECTROMAGNETIC BRAKE  
BRAKING TORQUE 15N·m FRAME NO. 90L

CUSTOMER

USER

FOR

CUST'S ORDER NO.

QUANTITY

UNIT(S)

MFG ORDER NO.

YOUR ORDER	KW·POLES	VOLT	HERTZ	MASS kg/UNIT	STYLE NO.
	1.5 kW 4P	380V	50Hz	26	

IE Code-Rated Eff	
1.5kW 4P	IE3-86.7%

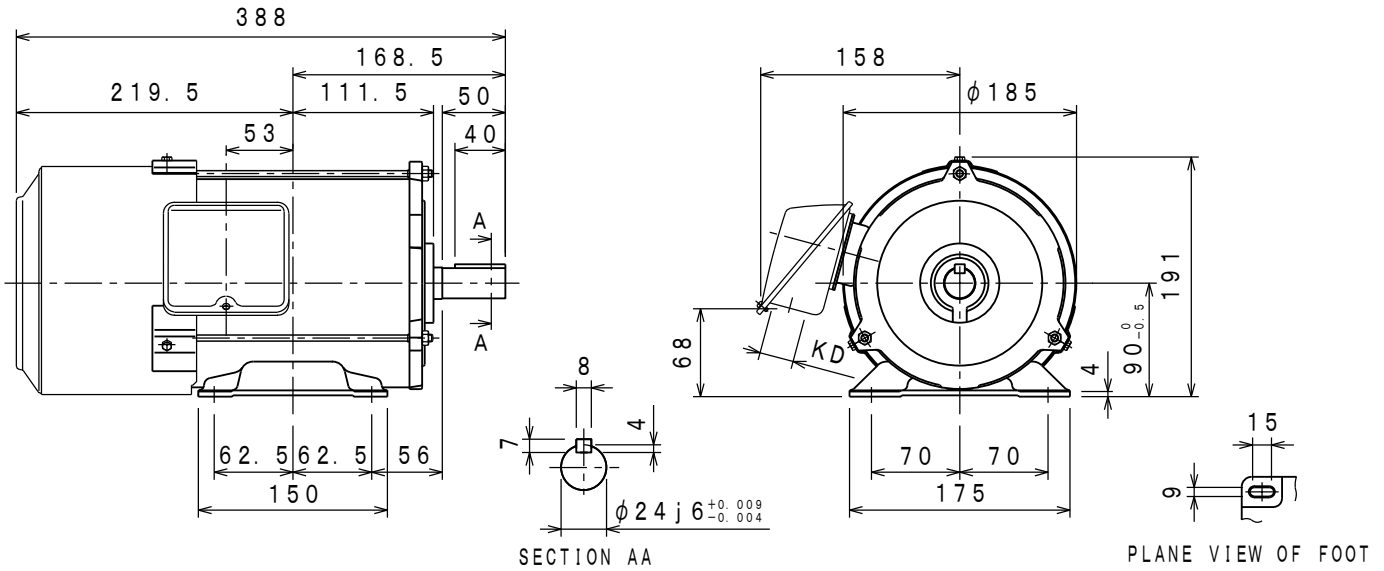

	RATING	THERMAL CLASS	AMB. TEMP	BEARINGS		NO. OF TERMINALS		VIEWED FROM DRIVE END		COLOUR	KD	BRAKING TORQUE
				LOAD SIDE	OPPOSITE SIDE	MOTOR	BRAKE	DIRECT. OF TERMINAL BOX	ROTATION			
	S 1	120 (E)	40° C	6205ZZ	6205ZZ	3	3	A (LEFT)	CCW	MUNSELL N7	φ 27	ABOVE 150%

- NOTE: 1. LEADS FOR MAIN POWER AND BRAKE ARE CONNECTED WITH TERMINAL BOARD, AND BRAKE IS TURNED OFF AT THE SAME TIME WITH MAIN POWER.  
IN CONNECTING THEM SEPARATELY, REMOVE BRAKE LEADS FROM TERMINAL BOARD.
2. WITH HALF WAVE RECTIFICATION METHOD DIRECT CURRENT POWER-SUPPLY UNIT (RECTIFIER) FOR BRAKE.  
FOR AC400V (INPUT VOLTAGE AC400/440/460V, OUTPUT VOLTAGE DC180/198/207V)
3. PLEASE REFER TO BD10783 FOR THE BRAKE CONNECTING WIRES.

	DRAWN	APPROVED
SCALE NTS		
DATE Dec. 20. '14		

(和文: BD27207)

MITSUBISHI ELECTRIC CORP., JAPAN  
NAGOYA WORKS

改型			

図面  
番号  
DWG. **BD27208-\***  
NO.

CAD(2D)