

MOTOR SPECIFICATION SHEET

MODEL : CHHM8-6165-43 (LT) (Motor model : SF-JRG 7.5HP 4P)

USED FOR : GEAR MOTOR

| DESCRIPTION | DETAIL | | | | |
|------------------------------------|---|------|------|------|------|
| PHASE | 3 | | | | |
| MODEL NAME | CHHM8-6165-43 | | | | |
| RATED OUTPUT, HP (kW) | 7.5 (5.5) | | | | |
| POLE | 4 | | | | |
| CODE | MEATH CODE : 1G1043-075H61651 | | | | |
| OUTLINE DRAWING NO. | OMM24O972-* | | | | |
| RATED VOLTAGE (V) | 220 | 380 | 415 | 220 | 440 |
| RATED FREQUENCY (Hz) | 50 | 50 | 50 | 60 | 60 |
| RATED CURRENT (A) | 20.4 | 11.8 | 11.1 | 19.9 | 10.3 |
| RATED SPEED (min ⁻¹) * | 33 | 33 | 33 | 40 | 40 |
| THERMAL CLASS | 155(F) | | | | |
| RATING | S1 (CONTINUOUS) | | | | |
| ENCLOSURE CONSTRUCTION | TOTALLY ENCLOSED FAN COOLED | | | | |
| DEGREES OF PROTECTION | IP55 | | | | |
| METHOD OF COOLING | IC411 | | | | |
| FRAME NO. | 132S | | | | |
| WEIGHT (kg) | 120 | | | | |
| STANDARD | IEC 60034-1, JEC-2137-2000 | | | | |
| INSTALLATION | FOOT MOUNTED | | | | |
| ROTATION | CCW (VIEWED FROM SHAFT END) | | | | |
| BEARING | LOAD SIDE : 6308ZZ | | | | |
| | OPPOSITE SIDE : 6207ZZ | | | | |
| BEARING GREASE | UREA GREASE | | | | |
| CIRCUMSTANCE CONDITION | AMBIENT TEMPERATURE : -20 ~ +40°C | | | | |
| | AMBIENT HUMIDITY : 95%RH OR LESS | | | | |
| | ABOVE SEA LEVEL : 1000m OR LESS | | | | |
| | ENVIRONMENT : NO BURSTING/EROSIVE GAS OR VAPOR | | | | |
| COLOR | MUNSELL N5.5 (GRAY) | | | | |
| TERMINAL BOX | NO. OF LEAD WIRES : 6 | | | | |
| | SOURCE CONNECTION : TERMINAL BLOCK | | | | |
| INSULATION RESISTANCE | BY DC 500V MEGGER - ≥100MΩ | | | | |
| DIELECTRIC TEST | AC 50Hz 1800V - 1min. (Based on rated voltage 380V) | | | | |
| GEAR RATIO | 1 : 43 | | | | |
| GEAR LUBRICANT | OIL (Must be filled by user.) | | | | |
| SERVICE FACTOR | 1.42 | | | | |
| MATERIAL | FRAME : STEEL PLATE | | | | |
| | BRACKET (GEAR SIDE) : CAST IRON | | | | |
| | BRACKET (OPP SIDE) : ALUMINIUM | | | | |
| | GEAR CASE : CAST IRON | | | | |
| | SHAFT (MOTOR) : STEEL | | | | |
| | SHAFT (GEAR OUTPUT) : STEEL | | | | |
| | STATOR CORE : ELECTRICAL STEEL | | | | |
| | WIRE : ENAMELLED COPPER MAGNET WIRE | | | | |
| | INSULATOR : POLYESTER FILM SATURATED WITH RESIN | | | | |
| | VARNISH : EPOXY DENATURALIZATION POLYESTER | | | | |
| | ROTOR CORE : ELECTRICAL STEEL | | | | |
| | CONDUCTOR : ALUMINIUM | | | | |
| | TERMINAL BOX : STEEL PLATE | | | | |
| PAINTING : POLYURETHANE RESIN | | | | | |
| PRODUCTION COUNTRY | THAILAND | | | | |

* This value is calculated by MOTOR RATED SPEED / GEAR RATIO.

(Catalog value is specified by follow Gear maker specification, 50/60Hz = 34/41min⁻¹.)

Specifications subject to change without notice.

| SPECIFICATION SHEET NO. | | | | |
|-------------------------|--|--|--|--|
| SS-M-2435-A | | | | |

MODEL CHHM THREE PHASE INDUCTION MOTOR OUTLINE DRAWING

GEAR MOTOR

TOTALLY ENCLOSED FAN COOLED

DEGREES OF PROTECTION IP55

DUST & WATER JET PROOF

CUSTOMER

USER

FOR

CUSTOMER'S

ORDER NO.

QUANTITY

MFG.

ORDER NO.

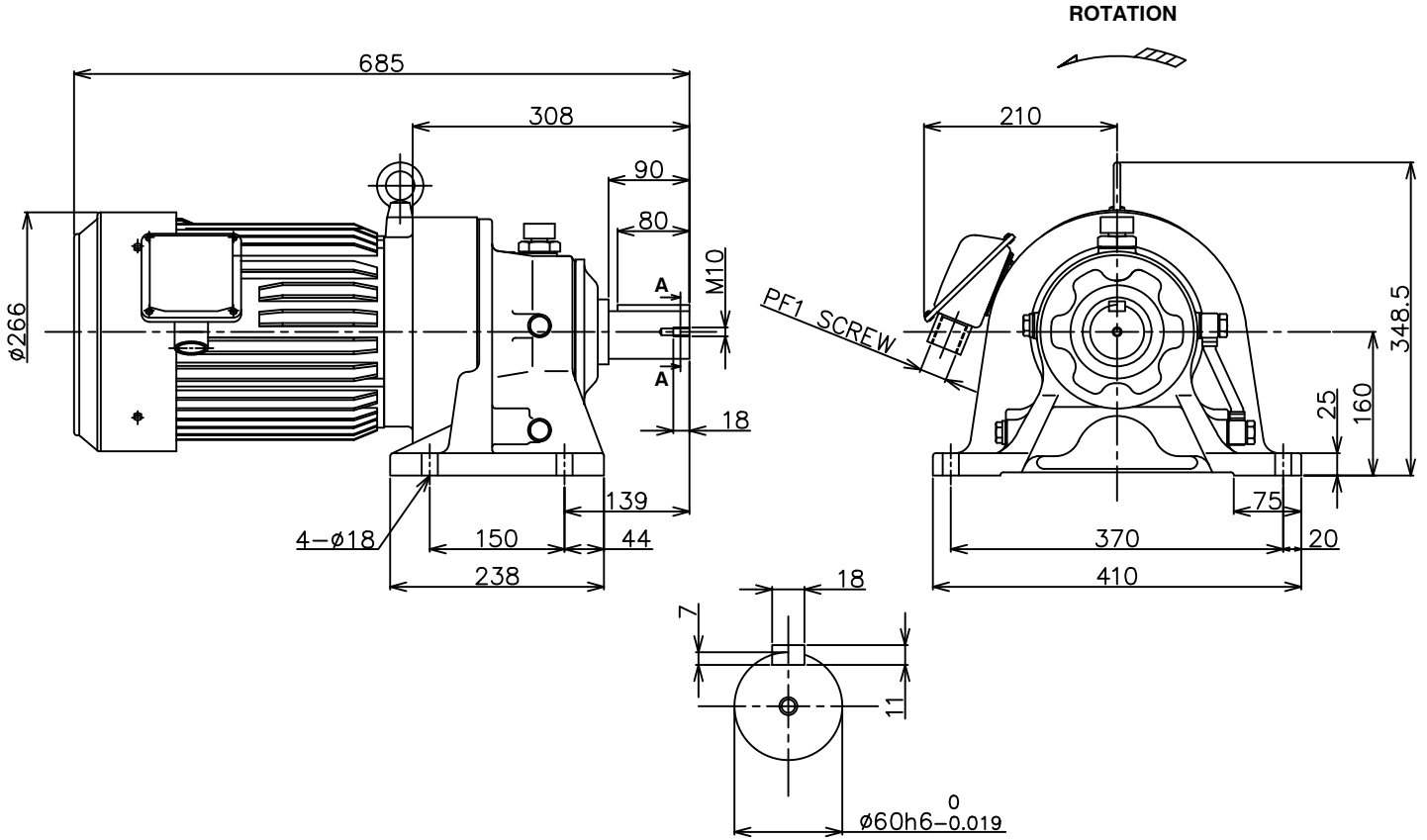

SECTION A-A

| YOUR ORDER | MOTOR FRAME SIZE | RATING | TH. CLASS | AMB. TEMP | BEARINGS | | COLOR | DIRECTION OF ROTATION | NO. OF LEAD WIRES | REMARKS |
|------------|------------------|------------|-----------|-----------|-----------|-----------|---------------------|-----------------------|-------------------|---------|
| | | | | | LOAD SIDE | OPP. SIDE | | | | |
| | 132S | S1 (CONT.) | 155(F) | 40°C | 6308ZZ | 6207ZZ | GRAY (MUNSELL N5.5) | CCW | 6 | |

| YOUR ORDER | MODEL NAME | RATIO | SERVICE FACTOR | MOTOR OUTPUT | | POLE | HERTZ | VOLT | OUTPUT SPEED (rpm) | LUBRICATION TYPE | WEIGHT (kg) |
|------------|---------------|-------|----------------|--------------|-----|------|-------|-------------|--------------------|------------------|-------------|
| | | | | HP | kW | | | | | | |
| | CHHM8-6160-35 | 1:35 | 1.46 | 7.5 | 5.5 | 4 | 50 | 220/380/415 | 41 | OIL (1) | 120 |
| | | | | | | | 60 | 220/440 | 50 | | |
| | CHHM8-6165-43 | 1:43 | 1.42 | 7.5 | 5.5 | 4 | 50 | 220/380/415 | 34 | | |
| | | | | | | | 60 | 220/440 | 41 | | |
| | CHHM8-6160-35 | 1:35 | 1.46 | 7.5 | 5.5 | 4 | 50 | 380/415 | 41 | | |
| | | | | | | | 60 | 380/440 | 50 | | |
| | CHHM8-6165-43 | 1:43 | 1.42 | 7.5 | 5.5 | 4 | 50 | 380/415 | 34 | | |
| | | | | | | | 60 | 380/440 | 41 | | |

NOTE : (1) Please fill in Oil before first time usage (See detail in the Instruction Manual)

MITSUBISHI ELECTRIC AUTOMATION (THAILAND) CO., LTD.

| | | | |
|--|---------------------------------|---|------------------|
| | | OUTLINE DRAWING NO. OMM240972 | REV. * |
| | DIMENSION IN mm. SCALE : NTS | | |