

MOTOR SPECIFICATION SHEET

MODEL : CNHM2-6120-29 (LT) (Motor model : SF-JRG 2HP 4P)

USED FOR : GEAR MOTOR

DESCRIPTION	DETAIL				
PHASE	3				
MODEL NAME	CNHM2-6120-29				
RATED OUTPUT, HP (kW)	2 (1.5)				
POLE	4				
CODE	MEATH CODE : 1G1029-020N61201				
OUTLINE DRAWING NO.	OMM94O966-*				
RATED VOLTAGE (V)	220	380	415	220	440
RATED FREQUENCY (Hz)	50	50	50	60	60
RATED CURRENT (A)	5.9	3.4	3.4	5.5	3.1
RATED SPEED (min ⁻¹) *	49	49	50	59	60
THERMAL CLASS	155(F)				
RATING	S1 (CONTINUOUS)				
ENCLOSURE CONSTRUCTION	TOTALLY ENCLOSED FAN COOLED				
DEGREES OF PROTECTION	IP55				
METHOD OF COOLING	IC411				
FRAME NO.	90L				
WEIGHT (kg)	41				
STANDARD	IEC 60034-1, JEC-2137-2000				
INSTALLATION	FOOT MOUNTED				
ROTATION	CCW (VIEWED FROM SHAFT END)				
BEARING	LOAD SIDE : 6205ZZ				
	OPPOSITE SIDE : 6204ZZ				
BEARING GREASE	UREA GREASE				
CIRCUMSTANCE CONDITION	AMBIENT TEMPERATURE : -20 ~ +40°C				
	AMBIENT HUMIDITY : 95%RH OR LESS				
	ABOVE SEA LEVEL : 1000m OR LESS				
	ENVIRONMENT : NO BURSTING/EROSIVE GAS OR VAPOR				
COLOR	MUNSELL N5.5 (GRAY)				
TERMINAL BOX	NO. OF LEAD WIRES : 6				
	SOURCE CONNECTION : TERMINAL BLOCK				
INSULATION RESISTANCE	BY DC 500V MEGGER - ≥100MΩ				
DIELECTRIC TEST	AC 50Hz 1800V - 1min. (Based on rated voltage 380V)				
GEAR RATIO	1 : 29				
GEAR LUBRICANT	GREASE (Filled from factory.)				
SERVICE FACTOR	1.91				
MATERIAL	FRAME : STEEL PLATE				
	BRACKET (GEAR SIDE) : CAST IRON				
	BRACKET (OPP SIDE) : ALUMINIUM				
	GEAR CASE : CAST IRON				
	SHAFT (MOTOR) : STEEL				
	SHAFT (GEAR OUTPUT) : STEEL				
	STATOR CORE : ELECTRICAL STEEL				
	WIRE : ENAMELLED COPPER MAGNET WIRE				
	INSULATOR : POLYESTER FILM				
	VARNISH : EPOXY DENATURALIZATION POLYESTER				
	ROTOR CORE : ELECTRICAL STEEL				
	CONDUCTOR : ALUMINIUM				
	TERMINAL BOX : STEEL PLATE				
PAINTING : POLYURETHANE RESIN					
PRODUCTION COUNTRY	THAILAND				

* This value is calculated by MOTOR RATED SPEED / GEAR RATIO.

(Catalog value is specified by follow Gear maker specification, 50/60Hz = 50/60min⁻¹.)

Specifications subject to change without notice.

SPECIFICATION SHEET NO.				
SS-M-9389-A				

MODEL CNHM THREE PHASE INDUCTION MOTOR OUTLINE DRAWING

GEAR MOTOR
TOTALLY ENCLOSED FAN COOLED
DEGREES OF PROTECTION IP55
DUST & WATER JET PROOF

CUSTOMER _____
USER _____
FOR _____
CUSTOMER'S ORDER NO. _____
QUANTITY _____
MFG. ORDER NO. _____

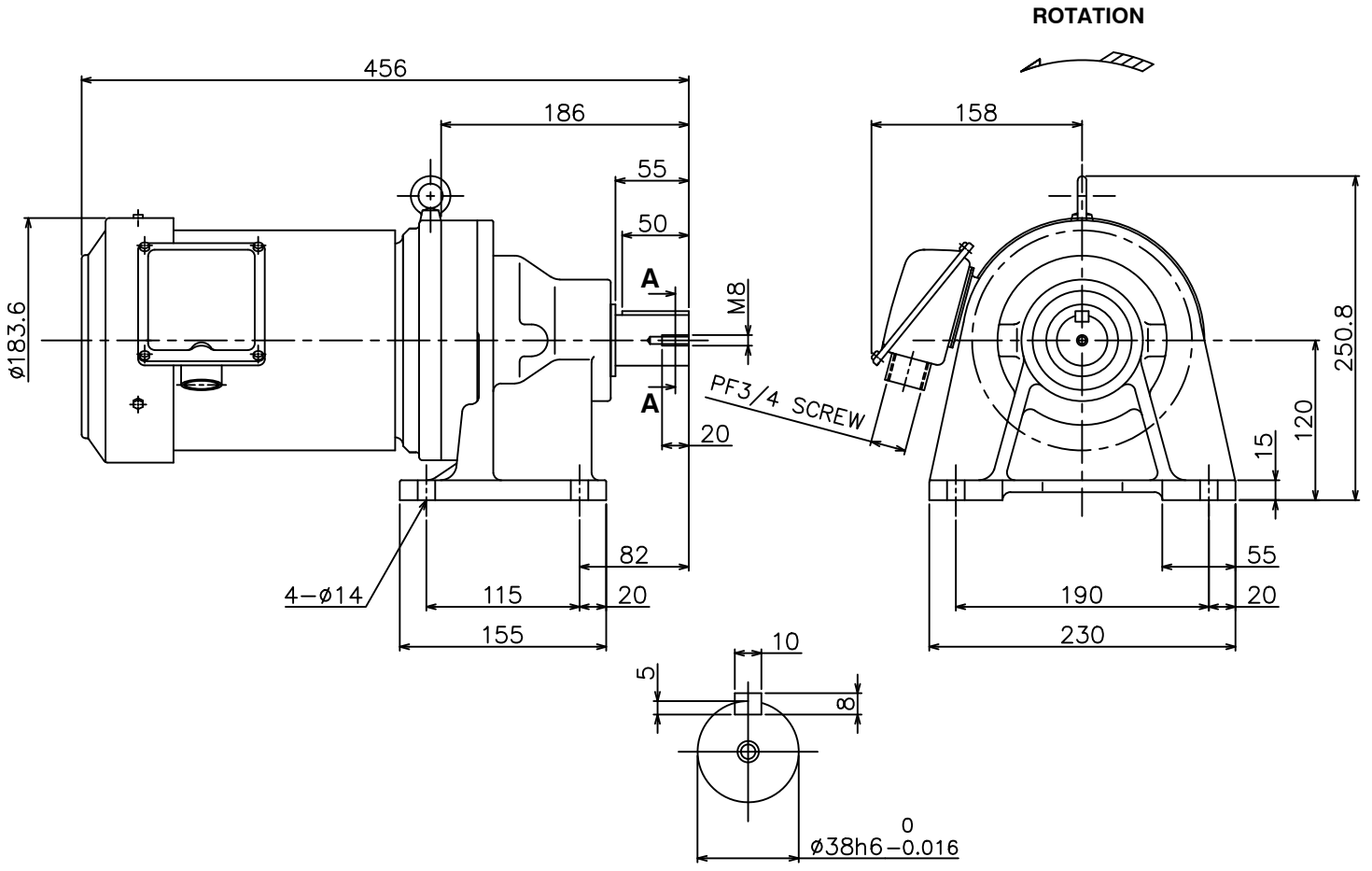

SECTION A-A

YOUR ORDER	MOTOR FRAME SIZE	RATING	TH. CLASS	AMB. TEMP	BEARINGS		COLOR	DIRECTION OF ROTATION	NO. OF LEAD WIRES	REMARKS
					LOAD SIDE	OPP. SIDE				
	90L	S1 (CONT.)	155(F)	40°C	6205ZZ	6204ZZ	GRAY (MUNSELL N5.5)	CCW	6	

YOUR ORDER	MODEL NAME	RATIO	SERVICE FACTOR	MOTOR OUTPUT		POLE	HERTZ	VOLT	OUTPUT SPEED (rpm)	LUBRICATION TYPE	WEIGHT (kg)
				HP	kW						
	CNHM2-6120-25	1:25	2.06	2	1.5	4	50	220/380/415	58	GREASE ⁽¹⁾	41
							60	220/440	70		
	CNHM2-6120-29	1:29	1.91	2	1.5	4	50	220/380/415	50		
							60	220/440	60		
	CNHM2-6120-35	1:35	1.58	2	1.5	4	50	220/380/415	41		
							60	220/440	50		
	CNHM2-6125-43	1:43	1.56	2	1.5	4	50	220/380/415	34		
							60	220/440	41		

NOTE : (1) Grease had been filled from manufacturer already.

MITSUBISHI ELECTRIC AUTOMATION (THAILAND) CO., LTD.

		OUTLINE DRAWING NO. OMM940966	REV. *
	DIMENSION IN mm. SCALE : NTS		